



CMAAA

CONCRETE MASONRY
ASSOCIATION OF AUSTRALIA

PA04

Concrete
Segmental
Pavements -
Maintenance
Guide

While the contents of this publication are believed to be accurate and complete, the information given is intended for general guidance and does not replace the services of professional advisers on specific projects. Concrete Masonry Association of Australia cannot accept any liability whatsoever regarding the contents of this publication.

Copyright © Concrete Masonry Association of Australia 2014.

ABN 33 065 618 804.

This publication, its contents and format are copyright of the Concrete Masonry Association of Australia, and may not be reproduced, copied or stored in any medium without prior, written authorisation from the Institute. Concrete Masonry Association of Australia is wholly sponsored by the Australian concrete brick, block and paver industry. Local or state regulations may require variation from the practices and recommendations contained in this publication.

The Standards referenced in this manual were current at the time of publication.

Cover: The Sydney Olympic Park was a major development that used over 7 million paving units across 17 different product lines. This was all laid by hand, in preparation for the 2000 Sydney Olympics. The design by Hassell Architects includes Olympic Boulevard and Plazas and Olympic Park Railway Station. Paving Contractors by Shannon Tower Pty and Sam the Paving Man.

Pavers: Adbri Masonry Honed Trihex®

Photography: Art One Advertising & Design – Alvaro Zaralli



PO Box 370, Artarmon NSW 1570 Australia
Suite 3.02, Level 3, 44 Hampden Road Artarmon NSW 2064 Australia
Telephone +61 2 8448 5500 Fax +61 2 9411 3801
ABN 30003873309

www.cmaa.com.au

CONCRETE MASONRY ASSOCIATION OF AUSTRALIA

CONCRETE SEGMENTAL PAVING – MAINTENANCE GUIDE

Dr Brian Shackel, Associate Professor

School of Civil and Environmental Engineering, University of New South Wales.

Alan Pearson, Executive Director

Concrete Masonry Association of Australia

CONTENTS

1	Introduction	2
2	Considerations for Trouble-Free Maintenance	2
3	Routine and Preventive Maintenance	3
4	Surface Maintenance	5
5	Structural Maintenance	6
6	Cleaning and Stain Removal	7
7	Sealing Concrete Segmental Paving	10
8	References	11

Disclaimer: The Concrete Masonry Association of Australia Limited is a non-profit organisation sponsored by the concrete masonry industry in Australia to provide information on the many uses of concrete masonry products. Since the information provided is intended for general guidance only and in no way replaces the service of professional consultants on particular projects, no liability can be accepted by the Association for its use.

Industry Support. Most of the manufacturers of quality concrete masonry products in Australia are members of the Concrete Masonry Association of Australia (CMAA). It is recommended that advice be obtained from local CMAA members to adapt or supplement information contained in this Guide.

Remember, when working with cement and concrete/mortar or manufactured or prefabricated concrete products, ALWAYS follow the manufacturer's instructions and seek advice about working safely with the products from the manufacturer, your nearest WorkCover Authority or Worksafe Australia.

1 Introduction

Concrete segmental paving has been widely used in Australia since the late 1970's in municipal pavements, roads, industrial and port facilities and airport pavements. Provided they are correctly designed and constructed, concrete segmental paving generally requires less structural maintenance than other forms of surface.

This document is for general guidance only and is not intended to replace the services of professional consultants. The Concrete Masonry Association of Australia Ltd and authors accept no responsibility for the consequences of implementing any action or procedure set out in this Guide.

2 Considerations for Trouble-Free Maintenance

Maintenance can be kept simple, straightforward and unobtrusive by adopting the following basic rules:

- **Stockpile.** Retain a small stockpile of pavers or flags for each pavement as it is constructed. For flags, the quantity of pavers needed for maintenance can be calculated on the basis of replacing 2% of the pavement surface per year of service life. For conventional pavers, smaller stockpile quantities are needed than for flags (typically < 2%). Paver dimensions change slightly as the manufacturing mould unavoidably wears. Also minor colour changes are likely to occur as concrete mix details vary during production. To overcome these paver variations when establishing a maintenance stockpile the units should be sampled from deliveries spaced throughout the construction period. Moreover, each batch of pavers kept for repairs should be stored and entered into an inventory so that they can always be clearly associated with a particular project.
- **Equipment.** Employ the right tools. As a minimum requirement the maintenance team should be equipped with extraction tools to remove pavers and rubber mallets and a plate vibrator for their reinstatement. The use of extraction tools will minimise the need to damage or destroy pavers that normally results from the use of levers and other unsuitable general purpose tools to lift pavers. Specialised mechanical handling equipment, such as suction-lifters should also be considered.
- **Recycling.** Pavers are unique amongst surfacings in respect of the ease with which they may be recycled. Do not squander this advantage! Remember that, to make an invisible repair, it is desirable to re-use as many of the original pavers as possible. Accordingly, always recover all undamaged pavers for reuse, preferably in their original location.
- **Blending.** Pavers weather in service and will therefore develop a different appearance from pavers kept in maintenance stockpiles. Where original and stockpiled pavers must be used together it is desirable to mix them to minimise obvious localised changes in the colour or texture of the repaired pavement surface.

3 Routine and Preventive Maintenance

As with other forms of surface, time and money can be saved by judicious use of routine preventive maintenance techniques for segmental paving. Maintenance should embrace the following activities.

- Regular cleansing of the pavements. Many materials (eg. leaves) will only stain or discolour pavers if they are allowed to remain in contact with the surface for prolonged periods. Accordingly, frequent sweeping and flushing of the surface will help maintain it in pristine condition. Cleaning techniques for segmental paving are discussed in **Chapter 6**.
- Where aesthetics considerations are paramount, an effective form of preventive maintenance may be to seal the pavements. This is discussed in **Chapter 7** of this Guide.
- Attention to maintaining the jointing sand will protect the structural integrity of the pavement. It may be necessary to refill the joints immediately following construction or where inappropriate cleansing actions (see **Chapter 6**) have been allowed to erode the sand. Usually this will only be necessary during the first few months of the pavement service life. Joints are best refilled using clean dry sand that is vibrated into the joints using a plate vibrator (**Clause 4.2.1**).
- Regular inspections should be made to identify incipient problems. Because the modular nature of paving facilitates spot repairs, major maintenance of large areas of surface can often be avoided provided prompt action is taken to fix small localised problems.

In planning maintenance operations it should be recognised that the costs of carrying out spot repairs are greater than the original construction costs. Not only are the costs of lifting the pavers more expensive than the laying costs but experience shows that the output of maintenance crews is typically only about half that achieved for new construction.

The common problems in concrete segmental paving requiring maintenance are summarised in **Table 1**. These can be categorised as

- **Maintenance of the pavement surface** involving maintenance of the joints, cleansing the surface, stain removal and lifting/replacements of only individual or small groups of pavers.
- **Structural maintenance** involving the removal of large areas of paving to allow the pavement sub-structure and drainage to be rectified or improved.

In the case of major rehabilitation where the entire pavement must be reconstructed the costs of lifting the paving can be reduced by a suitable choice of paver shape. For example, where rectangular blocks are used it is possible to lift the pavers en-masse using the bucket of a front-end loader without causing significant damage to the pavers. By contrast, dentated pavers may suffer considerable damage if excavated in this manner.

Table 1 *Principal Types of Maintenance*

SURFACE MAINTENANCE			
Symptom	Probable principal cause	Extent	Principal maintenance options
Occasional cracked pavers	Poor construction quality control of base layers	A few individual isolated pavers	Replace only if aesthetics are impaired
Cracked flagstones	Poor construction quality control or incorrect manufacturing specification	Individual flags or groups	Replace with new flags
Occasional chipped pavers or flagstones	Flags or pavers laid with inadequate (too narrow) joint widths	Individual pavers or flags	Replace only if aesthetics are impaired If joint widths < 2 mm, lift and re-lay so that all joints lie between 2 and 5 mm
Worn or abraded pavers or flags	Incorrect specification or poor quality control during manufacture/delivery	Individual or groups of pavers or flags	Replace only if aesthetics are impaired Lift and replace with units meeting requirements of T44 ⁽¹⁾ and MA44 ⁽⁴⁾
Pavers are standing proud of surface	Poor control of paver thickness	Upstand ≤ 5 mm Upstand >5mm	≤ 5 mm, ignore but continue to monitor surface > 5 mm, replace proud pavers with correct-height units
Joints have lost sand	Joints were not completely filled during construction, vacuum sweepers or water jets were used or insufficient chamfers were provided on pavers	Sand loss ≤ 10 mm deep Sand loss > 10 mm deep	≤ 10 mm, suspend vacuum sweeping/water jetting until problem is fixed > 10 mm, refill joints using dry jointing sand and recompact entire surface Consider use of proprietary bonded jointing sands
Joints support weed growth	Windblown seeds have propagated in the jointing sand	–	Spray with weedicides or herbicides
Surface is stained	Normal service conditions or insufficient routine cleansing	Individual or groups of pavers or flags	Clean or replace individual pavers if aesthetics are impaired Clean surface, insitu, for groups
Surface shows efflorescence	Soluble salt deposits	Groups of pavers or flags	Will disappear in time with vigorous brushing or acid wash No long-term maintenance necessary. Do not seal surface
STRUCTURAL MAINTENANCE			
Symptom	Probable principal cause	Extent	Principal maintenance options
Large areas of chipped pavers or flagstones with joint widths < 2 mm	Flags or pavers laid with inadequate (too narrow) joint widths or surface was installed on under-designed or poorly-constructed sub-structure	Groups of pavers or flags	Lift pavers, repair sub-structure and re-lay with new pavers or flags. Ensure joint widths are between 2 mm and 5 mm
Extensive areas of cracked pavers	Poor construction quality-control and/or inadequate pavement sub-structure	Groups of adjacent pavers	Lift pavers, repair sub-structure and re-lay with new pavers
Surface has been trenched	Normal service conditions	–	Check and compact trench backfill, reinstate original pavers and compact
Joints are pumping	Drainage of bedding sand is blocked or inadequate and/or incorrectly graded bedding and jointing sands were used	Localised areas of distress Widespread problem	Lift and re-lay area using original pavers with new bedding and jointing sand Check and, if necessary, lift pavers, rectify drainage and/or replace bedding sand, re-lay original pavers, refill joints with correctly graded or proprietary-bonded jointing sand and recompact pavement. Consider sealing pavement surface
Joint lines are distorted horizontally	Incorrect choice of paver shape or laying pattern to suit traffic	Displacement ≤ 10 mm Displacement > 10 mm	≤ 10 mm, if aesthetics are impaired lift pavers, loosen and rescreen sand, re-lay pavers > 10 mm, re-lay using Category A pavers in herringbone pattern
Surface exhibits undulations but no rutting	Basecourse was incorrectly profiled or toleranced during construction leading to variable bedding-sand thicknesses	Localised areas of distress Widespread distress	Lift and re-lay only if aesthetics and/or riding quality is impaired Lift pavers, remove and discard bedding sand, re-profile base and re-lay original pavers
Surface exhibits rutting along wheel paths	Sub-structure is inadequate due to poor design, sub-standard base materials or insufficient compaction	Ruts are continuous along pavement	If aesthetics or riding quality is impaired then lift pavers, remove bedding sand, repair sub-structure and re-lay original pavers on fresh bedding sand

4 Surface Maintenance

It may be seen from Table 1 that, where chipped, cracked or worn pavers significantly affect the appearance of the surface, they can be removed and replaced. In this respect it is emphasised that individual cracked pavers seldom impair the structural integrity of a segmental pavement even though the aesthetics may be adversely affected.

Where pavers stand proud of the surface they must be replaced before they constitute a trip hazard. The technique of opening and re-instating segmental pavements is discussed below.

4.1 Opening and Reinstatement of Segmental Pavements

To lift an area of paving it is first necessary to remove two or three pavers from the pavement. This creates sufficient space so that levers can then be used to prise out the remaining units over the full area to be repaired. In a properly constructed pavement the initial removal of pavers is seldom easy. Special extraction tools are available for paver removal but may be ineffective unless the joints are wide or are free of sand. In many cases it is necessary to attempt to lever out a paver using tools such as screwdrivers. If the pavement is tightly laid this will often cause chipping of the pavers and a quicker solution is simply to smash one or more blocks to establish an opening in the pavement.

It is normally found that, because of weathering, wear and staining, pavers removed from a pavement will differ in appearance from those in the maintenance stockpile. For this reason, as the pavement is lifted, all undamaged pavers should be retained for later re-use. Where it is necessary to replace smashed or damaged pavers with units drawn from the maintenance stockpile it is important to blend the old and new pavers over the area being repaired to reduce the visual impact of any colour variation.

The bedding sand exerts a crucial influence on segmental pavement performance under traffic. For this reason, where it is necessary to excavate the bedding sand, it should be discarded rather than be retained for re-use, as it is likely that the sand will become contaminated or degraded during the repair process. Before removing the sand its thickness should be measured because it is important that the replacement layer be reinstated to as near the same thickness as practical. This will avoid variations in the behaviour of the pavement under traffic due to changes in the bedding sand thickness. This usually requires screeding the replacement sand to a loose thickness about 10—15% greater than the target thickness.

4.2 Joint Maintenance

4.2.1 Joint Filling

Segmental pavements develop their structural capacity by wedging action between the individual pavers caused by traffic. The forces generated by this wedging action can only be transmitted through the pavement if the joints remain full of sand. Maintenance of the joints is therefore very important in maintaining the structural performance of segmental paving. Any loss of sand in the joints below the level of the chamfers should be promptly rectified. This is best accomplished by using dry bagged jointing sand meeting the requirements of T45⁽²⁾. This sand should be brushed repeatedly across the joints until they are completely filled. Excess sand should be broomed off and the pavement should be compacted by at least 3 passes of a plate compactor. This process may need to be repeated several times until the joints are completely filled. This is best accomplished when the pavement is completely dry.

4.2.2 Joint Stabilisation

In areas where there is an occasional flow of water across the pavement surface and where vacuum sweepers are used, consideration should be given to stabilising the jointing sand using a sealant. This is discussed further in Chapter 6 of this Guide. Alternatively, proprietary jointing sands are available to fill the joints. These normally bind together upon wetting.

4.2.3 Weed Control

Best controlled by periodic applications of weedicide. Best results will often be achieved in dry weather when the pavement is dry prior to using the weedicide.

5 Structural Maintenance

Structural maintenance becomes necessary when the pavement has been trenched or where the cause of pavement distress lies either in a poor choice of paver shape, laying pattern or because of problems in the base, sub-base or subgrade of the pavement.

5.1 Trenching

In opening an area of pavement to be trenched or repaired the width of paving lifted should provide an adequate working space of at least 1 m and should extend beyond the edge of any excavation by at least two runs of pavers. Because of the horizontal forces that develop in block pavements during construction and under traffic it is good practice to insert toms and spreaders across the excavation as shown in **Figure 1**. These prevent the pavement creeping horizontally inwards towards the area being repaired. If this is not done it may be difficult or impossible to reinstate the pavers once repairs to the pavement substructure are complete. In restraining the pavers it is not necessary to support the entire length of pavers around the repair. Usually it is adequate to space the toms and spreaders, shown in **Figure 1**, at intervals of 2–3 m.

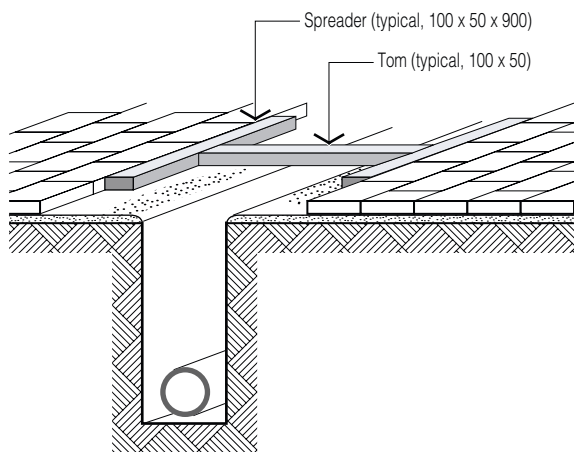

Figure 1 Use of Toms and Spreaders at an Excavation.

Concrete segmental paving is unique amongst surfacings in that repairs can be made without leaving traces of the excavation. However, to accomplish this needs care in backfilling the excavation. Where possible clay material should be discarded and the excavation should be backfilled with layers of granular material. Each layer should be not more than 150-mm thick and should be fully compacted before placing subsequent layers. Occasionally, it is advantageous to add small quantities of cement (1% to 1.5% by weight) to help reduce subsidence. A common mistake by maintenance crews is to pay insufficient attention to the finished levels of the backfill on the assumption

that errors in level can be corrected by varying the bedding sand thickness. However, this is poor practice and efforts should be made to maintain the sand thickness uniform to avoid differential deformations under traffic. As noted above, fresh sand should be installed to the original thickness. This normally means screeding the sand to a loose thickness some 10 to 15 percent greater than the target thickness.

The pavement should be relaid using those pavers removed from the excavation blended with essential replacements drawn from the maintenance stockpile. Toms and spacers should be removed progressively as the reinstatement of the surface proceeds. The compaction applied to the reinstated pavers should be as heavy as practical.

In the case of major rehabilitation where the entire pavement must be reconstructed the costs of lifting the paving can be reduced by a suitable choice of paver shape. For example, where rectangular blocks are used it is possible to lift the pavers en-masse using the bucket of a front-end loader without causing significant damage to the pavers. By contrast, dentated pavers may suffer considerable damage if excavated in this manner.

5.2 Creep in the Joint Lines

Distortion or creep of the joint lines is usually caused by traffic and is most evident in the wheel paths. Unless this is allowed to progress to a point at which the pavers become loose and are able to rotate, creep is primarily a problem of aesthetics and has little effect on the structural integrity of the pavement. As a rule of thumb, creep movements of 10 mm or less can usually be ignored unless aesthetic considerations are paramount.

Creep in the joint lines can only be remedied by lifting and relaying all or part of the surface. Unless the creep movements of the joint lines are accompanied by rutting it is normally not necessary to disturb the pavement substructure. Rather, following removal of the pavers it is sufficient to loosen and re-screed the bedding sand and then re-lay and compact the pavers. Often this will need to be done kerb to kerb but, as a minimum requirement, the pavers should be removed back to areas where the joint lines remain straight

However, simply to lift and re-lay the pavers may not permanently fix the problem of creep which, especially in the wheel paths, can be caused by the choice of paver shape or laying pattern. Where the pavers have been laid in stretcher bond the problem of creep may be sometimes be corrected by lifting the pavers and relaying them in herringbone pattern. However, where rectangular or other Category C shapes according to T44⁽¹⁾ and T45⁽²⁾ have been used this may prove futile in the long term. It is then usually necessary to lift and discard such pavers and to replace them with Category A shape pavers installed in herringbone bond.

5.3 Joint Pumping

Occasionally water may pump from the joints of a segmental pavement. Usually this is an indicator that the bedding sand drainage is not working correctly or has not been installed. This may also indicate the use of an inappropriate bedding sand not meeting the requirements of T45⁽²⁾ for pavers or MA44⁽⁴⁾ for flags. To remedy this problem normally requires the pavers or flags to be lifted so that the drainage system can be inspected and repaired. However, where the problem is minor and intermittent, consideration should be given to sealing the surface. This is discussed further in Chapter 7.

5.4 Undulating Surface

The most common cause of an undulating surface is poor control of the levels on the top of the basecourse leading to uneven thicknesses of bedding sand. Occasionally in pedestrian pavements, it may be possible to correct this problem by rolling the pavement with heavy pneumatic tyred rollers. More commonly it is necessary to lift the pavers, remove and discard the bedding sand and to carefully reprofile the basecourse to meet the tolerances set out in T45⁽²⁾. Fresh bedding sand can then be spread and the original pavers relaid. Such techniques should only be used where there is no rutting in the pavement, ie where there is no cause to question the structural adequacy of the base/sub-base. If rutting is present complete reconstruction of all or part of the pavement may be necessary (see Clause 5.5).

5.5 Rutting, Potholing or Extensive Surface Damage

Rutting or extensive cracking of pavers is symptomatic of inadequate support from the pavement sub-structure. If widespread, this may be the consequence of poor design, sub-standard materials or inadequate compaction. In such cases it is usually necessary to completely rebuild the affected lengths of pavement. This is beyond the scope of this Guide and reference should be made T45⁽²⁾, MA44⁽⁴⁾ or other Design Guides.

If the problems are localised, eg as potholes or depressions, it is often adequate merely to excavate the affected areas and to backfill these with well-compacted cement-treated granular materials and then to reinstall the pavers on fresh bedding sand. However, before implementing such relatively expensive maintenance procedures it is advisable to check that the pavement is adequately designed to resist the prevailing traffic conditions.

6 Cleaning and Stain Removal

6.1 Routine Cleaning

Concrete segmental pavements can be routinely cleaned just like any other pavement. However, precautions must be taken during the very early life of the pavement to avoid removing the jointing sand during cleansing operations. In particular, unless the pavement has been sealed (see Chapter 7), the use of vacuum sweepers and water jets should be avoided until the joints have become naturally-clogged with detritus. This normally occurs once the pavements have been open to traffic for two to three months. Until this occurs it is prudent to operate street sweepers without vacuum using their brushes only. Once the joints have become naturally-clogged vacuum sweepers and water jets can normally be used without problem.

Irrespective of whether the pavement has been sealed or allowed to clog naturally the condition of the joints should be periodically monitored once routine cleaning operations commence. Any procedure that leads to loss of jointing sand should be modified or suspended until the problem is rectified because experience has shown that inappropriate cleansing can lead to the failure of pavements carrying traffic if the joints lose too much sand.

6.2 Stain Removal

Many materials such as leaves will stain pavers only if they are left in prolonged contact with the pavement. Accordingly, the best strategy to keep a pavement in pristine condition is to ensure that all rubbish and leaves are regularly removed using sweepers and thereafter, the pavement is flushed with water. The use of water alone to flush debris from the pavement is not recommended because this will often concentrate organic materials likely to cause staining in low lying areas and adjacent to drains.

Staining can be minimised by sealing the pavements (see Chapter 7) or its impact can be reduced by using multi-coloured pavers. Light, non-penetrating stains can often be removed by brushing with a stiff broom in conjunction with a light application of sharp sand. Where persistent stains do occur they can be removed using a variety of chemicals and proprietary cleansing agents. These must be chosen with regard to occupational health and safety and the environmental impacts of runoff etc. As a general guide, information on stain removal is provided in Table 2. Broadly these methods fall into the following categories⁽⁶⁾:

- **Spotting.** Isolated spots of materials such as soil, bitumen, chewing gum or mortar should be scraped to remove excess material. This should be done before using chemicals or attempting widespread cleaning.

- **Dry brushing** with hand or mechanical brooms. This can be aided by a light application of clean sharp sand that can be swept up and removed after the stain is gone. The brooms should be fitted with fibre, plastic or brass bristles. The use of steel bristles should be avoided.
- **Wet scrubbing** using abrasive or scouring compounds followed by washing with water
- The use of **high-pressure water jets** operating at pressures up to about 14 MPa with flow rates up to 40 litres/min. Use low water pressures (< 1 MPa) to remove efflorescence with proprietary cleaning chemicals. Use higher water pressures to remove stains. The use of detergents and scrubbing with stiff brushes may be needed to supplement jetting for stubborn stains. Water jets are best handled by experienced professional cleaners.
- The use of **chemical pastes or poultices** that can be applied to the paver surface to remove spots of material such as tar or creosote.
- **Acid washes.** These are sometimes selected to permanently remove cement or mortar residues or to temporarily remove efflorescence. Acids should not be allowed to drain onto landscaped areas. Barriers of lime spread around the areas being cleaned can neutralise the acid but care must be taken to sweep up and remove this material once cleaning is complete. Acids are sometimes usefully combined with detergents in proprietary compounds for general purpose cleaning.

The methods set out in **Table 2** are for general guidance only. Stain removal is seldom accomplished without visible and often permanent changes to the colour and texture of the pavers. For this reason any stain removal compound should be treated with caution. Indeed, in many cases, where staining is localised, it may be preferable to replace the discoloured units with pavers drawn from the maintenance stockpile rather than to attempt to clean them. This is of particular relevance in the case of pavers stained with asphalt or oil because such stains are difficult to remove completely irrespective of the type of chemical used. However, paver replacement can be more expensive than insitu cleaning.

6.3 Efflorescence⁽⁶⁾

The most common cause of segmental paving discolouration is efflorescence. This is a transitory phenomenon and will usually disappear in time under abrasion by pedestrian or vehicular traffic. In the short term, efflorescence may be temporarily removed by stiff brushing or the application of a hydrochloric-acid-based cleaner, which must be flushed from the pavement after use. Extreme care is required when handling acids and safety precautions should be taken. Only diluted acid should be used to clean concrete surfaces. The recommended maximum proportions are 1 part hydrochloric acid to 20 parts water. Repeated use of acid-based cleaners is not recommended as this can actually increase efflorescence.

6.4 Choice of Stain Removal Method

The choice of stain removal method should be governed by the following considerations:

- The colour (pigmentation) of pavers is contained within the cement paste on the paver surface. Over-enthusiastic or inappropriate use of abrasives or acids may remove or destroy this paste and, thereby, cause irreversible alterations in the surface colour and texture.
- Brushing (with or without the use of sand) and water jetting should be tried before resorting to chemical stain removers.
- Compounds that have been developed specifically for cleaning pavers are usually preferred to generic materials such as those listed in **Table 2**.
- Do not mix different chemicals together as this may produce unpredictable or unsatisfactory results.
- In the absence of experience, assess the efficacy of a cleaning compound or procedure by a trial on a small inconspicuous area of the pavement.

6.5 Stain Removal Procedures

The recommended sequence for removing stains is as follows:

- Remove the worst stains first.
- Where abrasives, detergents or chemicals are used, ensure that all residues are immediately removed from the pavement surface.
- Do not allow liquid runoff to collect on the pavement surface or in the drains.
- Clean the entire pavement surface so that any colour variation is evenly distributed.

Table 2 *Methods of Stain Removal*

Source	Type of stain	Action
Plant, animal and vegetable matter	Moss, fungi and mould	Dry brushing with or without application of clean sharp sand OR High pressure water jetting with or without detergent OR Apply fungicides (Note, some fungicides may discolour pavers)
	Leaf mould	Use ordinary bleach or calcium chloride followed by sodium hypochlorite dissolved in water (1 kg in 5 litres) then scrub with stiff brush
	Wood rot	Use ordinary bleach or calcium chloride followed by sodium hypochlorite dissolved in water (1 kg in 5 litres) then scrub with stiff brush
	Linseed oil	Use trisodium phosphate/sodium perborate dissolved in hot water
	Tobacco	Use ordinary bleach then scrub with stiff brush
	Smoke	Scrub with poultice of talc and bleach diluted in water (1:5) and wash with water
Food	Blood	Apply liquid detergent for 15 to 20 minutes, scrub with hot water and rinse surface
	Mustard, tomato sauce and grease	Use detergent and hot water For stubborn stains apply undiluted liquid detergent for 15 to 30 minutes, then scrub and wash with hot water
Vehicles	Chewing gum	Scrape off excess material and apply poultice of methylated spirit OR Freeze gum with ice, carbon dioxide aerosol, or dry ice then remove by scraping, brushing or high-pressure water jets
	Oil or vehicle grease	Apply dry absorbents such as Fullers earth, talc, diatomaceous earth or kitty litter for 24+ hours to remove excess oil, then sweep up
Construction and building	Tyre marks	Scrub using stiff brush with aid of water, detergent and scouring powder or sharp sand
	Bitumen or tar bituminous emulsion	Freeze with ice, carbon dioxide aerosol, or dry ice, remove excess by scraping, scrub with scouring or abrasive powder and thoroughly wash with water
	Cutback bitumen	Apply poultice of kerosene in talc or diatomaceous earth, scrub, allow to dry then sweep off. Repeat as necessary
	Caulking compound (non-acrylic)	Scrape off excess material and apply poultice of methylated spirit and talc. Rinse with hot water and detergent
	Caulking compound (acrylic)	Soak area and scrub with stiff brush using hot water and scouring powder
	Creosote	Apply poultice of paint thinner in talc, scrub and allow to dry. Scrape off excess, scrub with scouring powder then wash with water
	Wet latex paint	Absorb with paper or cloth. Scrub with stiff brush using hot water and scouring powder
	Wet non-latex paint	Absorb with paper or cloth. Allow remaining paint to dry then proceed as below for dry paint
	Dry paint	Scrape off excess paint, apply paint remover for 15 to 30 minutes, loosen with gentle scrubbing and absorb loosened material with paper or cloth. Do not rub. Repeat as necessary
	Fresh Mortar	Cover with clean damp sand. Sweep off with stiff broom. Repeat as necessary. Apply clean dry sand and allow to dry
Hardened mortar	Hardened mortar	Remove lumps of hardened material by chiseling, scraping or grinding. Wet the surface then apply dilute hydrochloric acid (1 part acid to 20 parts of water) and scrub vigorously for 2 to 3 minutes. Thoroughly hose down the area immediately after scrubbing
	Efflorescence	Efflorescence will naturally disappear over time. In the short term, it can be removed with water jetting with proprietary chemicals followed by brushing. Alternatively, weak diluted (1:20) hydrochloric acid cleaners can be used followed by thorough flushing with water
Clay	Scrape off lumps then scrub with hot water and strong detergent	

Warning – when using chemicals:

- Diluted hydrochloric acid, chlorine bleach or chemically-based cleaning agents can be hazardous if used incorrectly.
- Read supplier's instructions before use.
- Observe safety advice and recommended dilution rate.
- Always add acid to water, not water to acid.
- Wear suitable protective clothing at all times and work only in well-ventilated areas. (protective clothing cartoon)
- Acids can etch the concrete surface. Use only diluted acids and wash off immediately after use, make sure application is evenly distributed over the surface area and avoid ponding.

7 Sealing Concrete Segmental Paving

Although a wide range of compounds are marketed as sealants for segmental paving, tests have shown that few are totally successful in preventing the infiltration of water into the pavement⁽⁵⁾.

Nevertheless, concrete segmental pavements may be usefully sealed for the following reasons:

- To stabilise the jointing sand. Here the sealant's prime function is to bind the jointing sand together and make it resistant to erosion, eg by propeller wash or jet wash in airports or by vacuum sweepers in downtown areas. The only time when sealing is compulsory is in airport pavements.
- To minimise staining of the surface in malls around food outlets, garbage bins, or in areas where oil droppings are common such as at bus stops, taxi ranks or traffic light stop lines. Sealants accomplish this by reducing the absorption. This makes the pavers less susceptible to staining from oil droppings or from food and drink spillages.
- For aesthetic reasons. In this respect some sealants deepen the colour of the pavers and/or add a glossy sheen.

In deciding whether or not to seal a pavement to prevent staining or for aesthetic reasons it should be understood that most sealants will wear away under pedestrian or vehicular traffic and must therefore be renewed periodically to retain their appearance and durability. Depending on the sealant chosen and the abrasion load, coatings will have a life of between about 1 and 3 years. Sealants must therefore be regarded as requiring regular renewal at frequencies determined by the pedestrian or vehicular traffic to be carried by the pavement.

7.1 Choice of Sealant

Increasingly, the choice of sealant is governed by environmental regulations. Until recently, most sealants were solvent based. Such materials are not environmentally-friendly because they release volatile hydrocarbons into the atmosphere as they cure. For this reason water-based sealant emulsions have been developed. However, compared to solvent-based sealants, these do not penetrate as deeply into the paver surfaces and take longer to cure.

Sealants fall into 3 main classes. These comprise:

- **Silanes and Siloxanes.** These materials are most commonly solvent-based although water-based alternatives have been developed which have the disadvantage of very short shelf lives. These sealants form hydrophobic barriers to the movement of water in the liquid phase but allow the movement of water vapour. They also tend to darken the colour of pavers. They are principally used as concrete sealants, eg to control efflorescence and to prevent the penetration of chloride ions into the concrete. This is of value in areas such as pool surrounds or along ocean beach promenades.
- **Acrylics.** These materials can be either solvent- or water-based and are often less expensive than other forms of sealant. They deepen the colour of pavers and can add a "wet look" gloss to the surface. In choosing an acrylic sealant care should be taken to select a material specifically developed for paving to ensure that it will not yellow over time. It should be noted that, although solvent-based acrylics remain stable at temperatures as high as 60°C, water-based acrylics may soften and degrade at high temperatures. Acrylics can be easily resealed if the surface becomes worn.
- **Urethanes.** Urethanes can be solvent- or water-based. They can be made fuel- and UV-resistant. They are inherently more resistant to chemical attack than acrylics but tend to be more expensive. Their principal uses are for jointing sand stabilisation in airport pavements, for petrol stations and for industrial pavements. They also enhance paver colours and provide a surface sheen.

7.2 Application of Sealants

Before sealing a pavement it should be thoroughly cleaned and allowed to dry completely. Pavements, which exhibit efflorescence, should not be sealed until this problem is remedied. For small areas, of about 100 m² or less, the sealant can be applied by hand rollers. Larger areas are more economically sealed using low-pressure sprayers or powered rollers. Care must be taken to avoid wind-borne spray carrying beyond the pavement.

Where urethanes are used to stabilise the sand in the joints they should be applied using rubber squeegees. These are used to wipe the sealant from the paver surfaces and to concentrate it in the chamfers along the top of the joints. Sufficient sealant should be applied to penetrate about 15 mm into the jointing sand. With care, a single application of sealant is usually sufficient.

8 References

- 1 T44 *Concrete Segmental Pavements – Guide to Specifying*, CMAA 1997.
- 2 T45 *Concrete Segmental Pavements – Design Guide for Residential Accessways and Roads*, CMAA 1997.
- 3 T46 *Concrete Segmental Pavements – Detailing Guide*, CMAA 1997.
- 4 MA44 *Concrete Flag Pavements – Design and Construction Guide*, CMAA 2000.
- 5 Shackel B. *An Experimental Study of Methods for Sealing Concrete Block Pavements*; Proceedings – Third International Workshop on Concrete Block Paving, Colombia, May 1998.
- 6 MA41 *Concrete Masonry Structures – Cleaning and Maintenance*, CMAA 2000.

PO Box 370, Artarmon NSW 1570 Australia
Suite 3.02, Level 3, 44 Hampden Road Artarmon NSW 2064 Australia
Telephone +61 2 8448 5500 Fax +61 2 9411 3801
ABN 30V003873309
ISBN 0 909407 47 9
www.cmaa.com.au

